

Detail 25 XXL-1-6

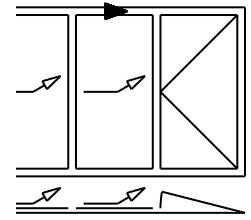

Detail 25 XXL-1-7

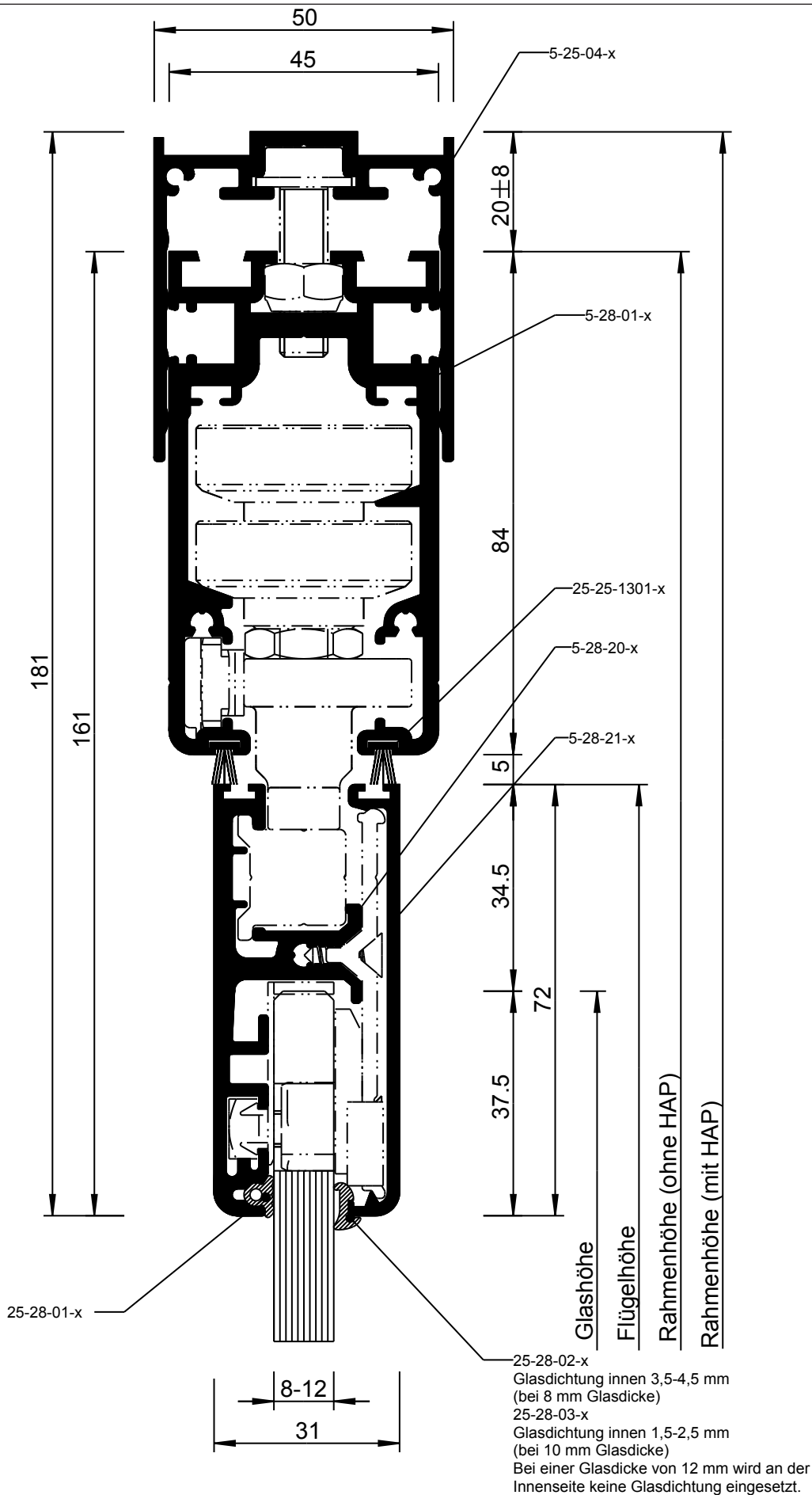
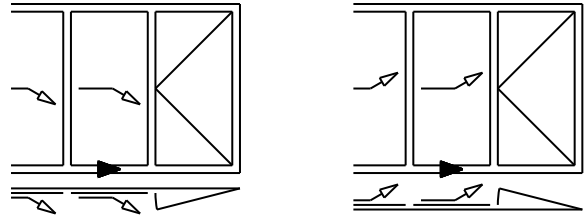

Detail 25 XXL-2-2

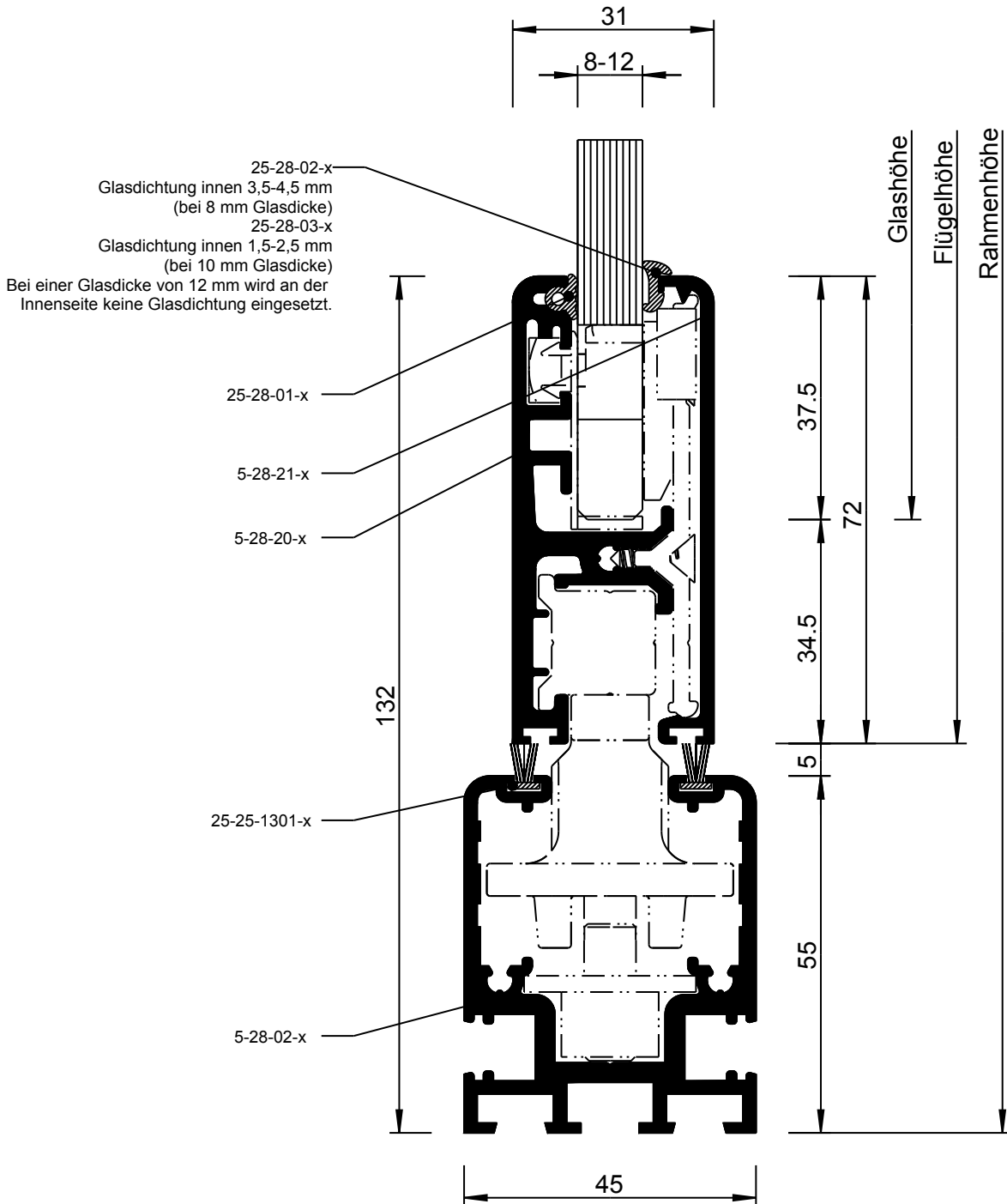

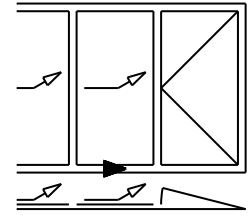
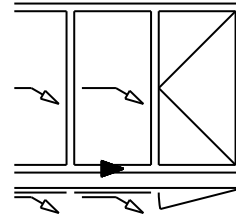

Detail 25 XXL-2-4

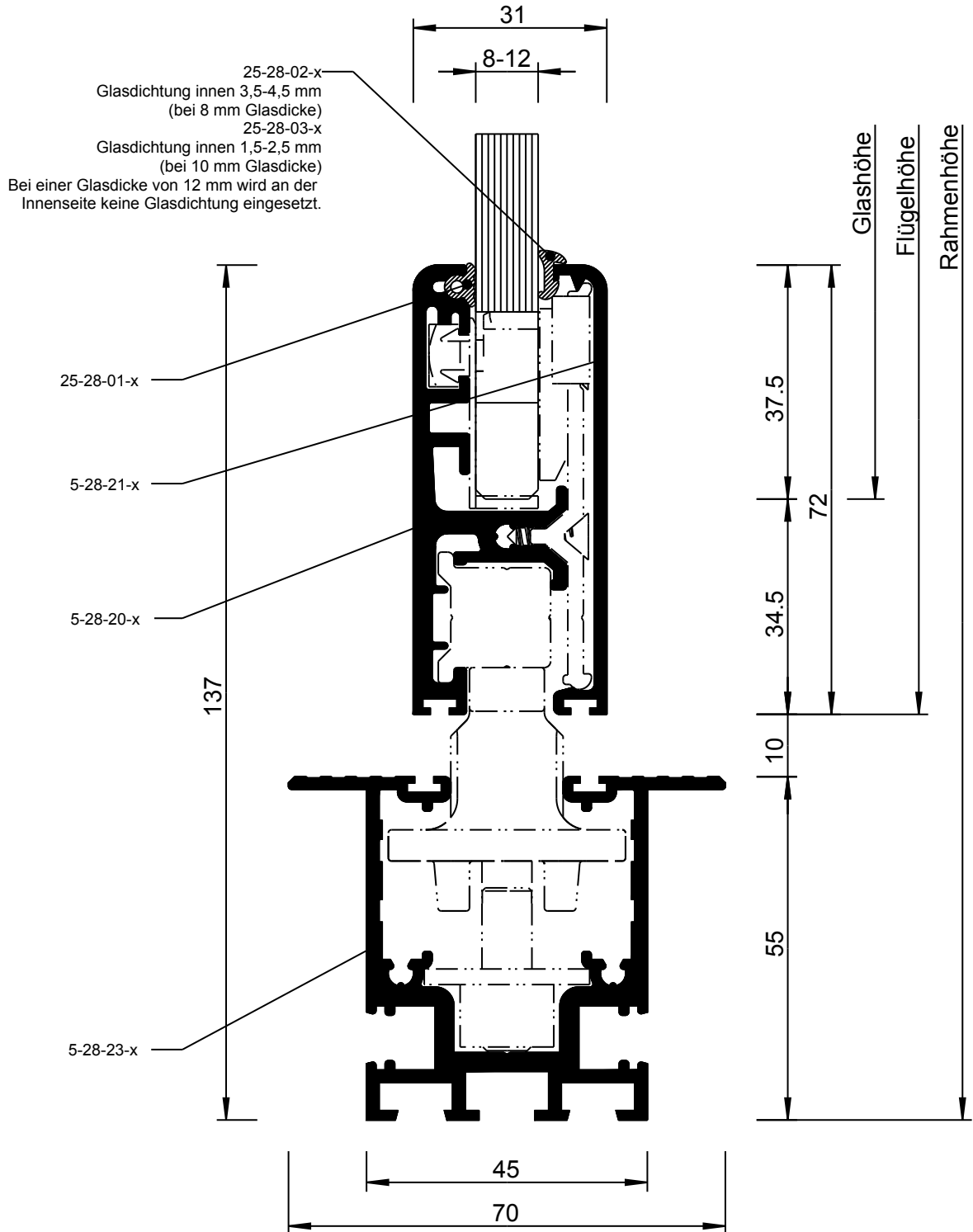

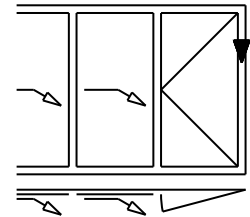

Detail 25 XXL-3-2

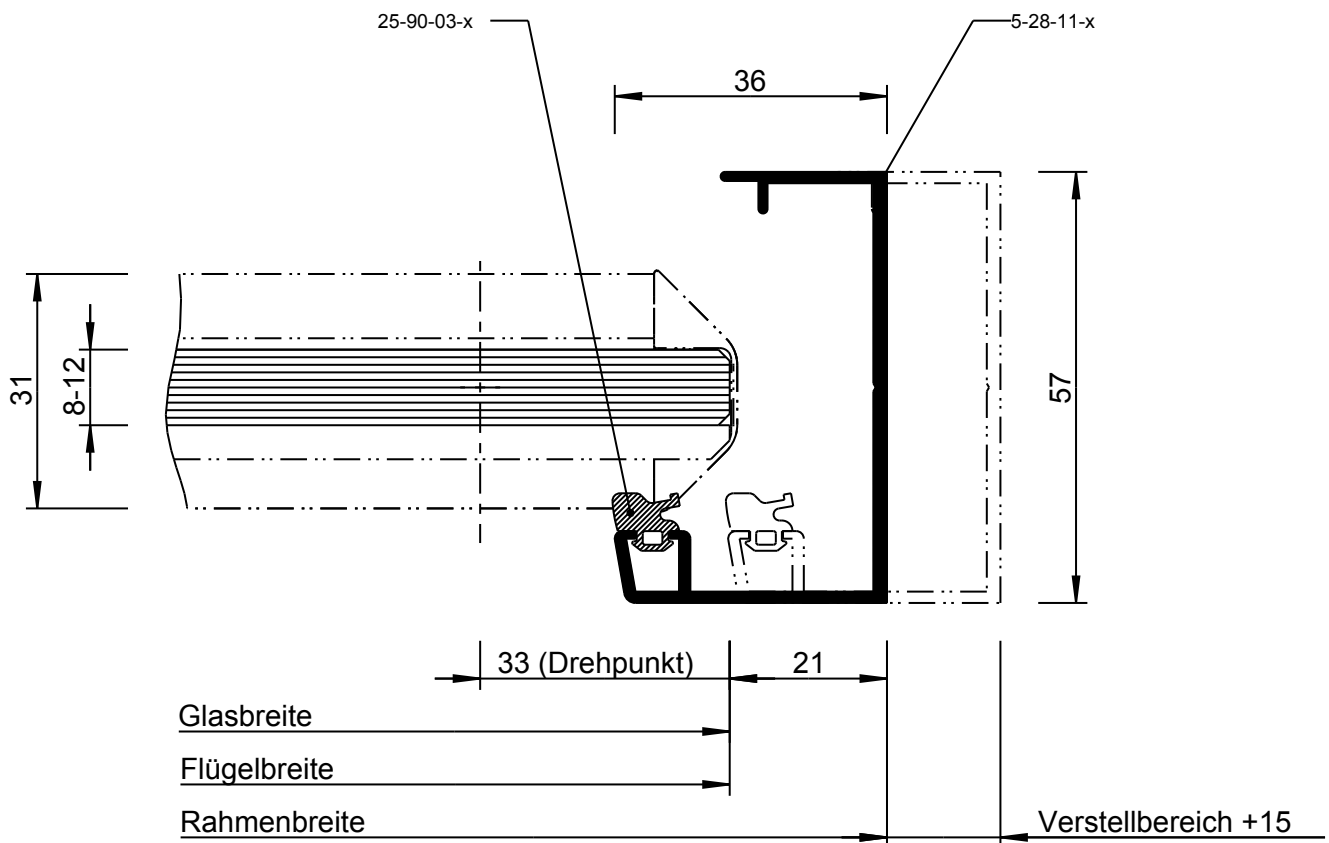

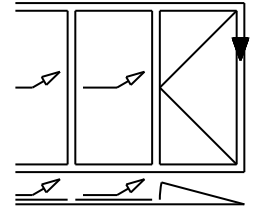

Detail 25 XXL-3-3

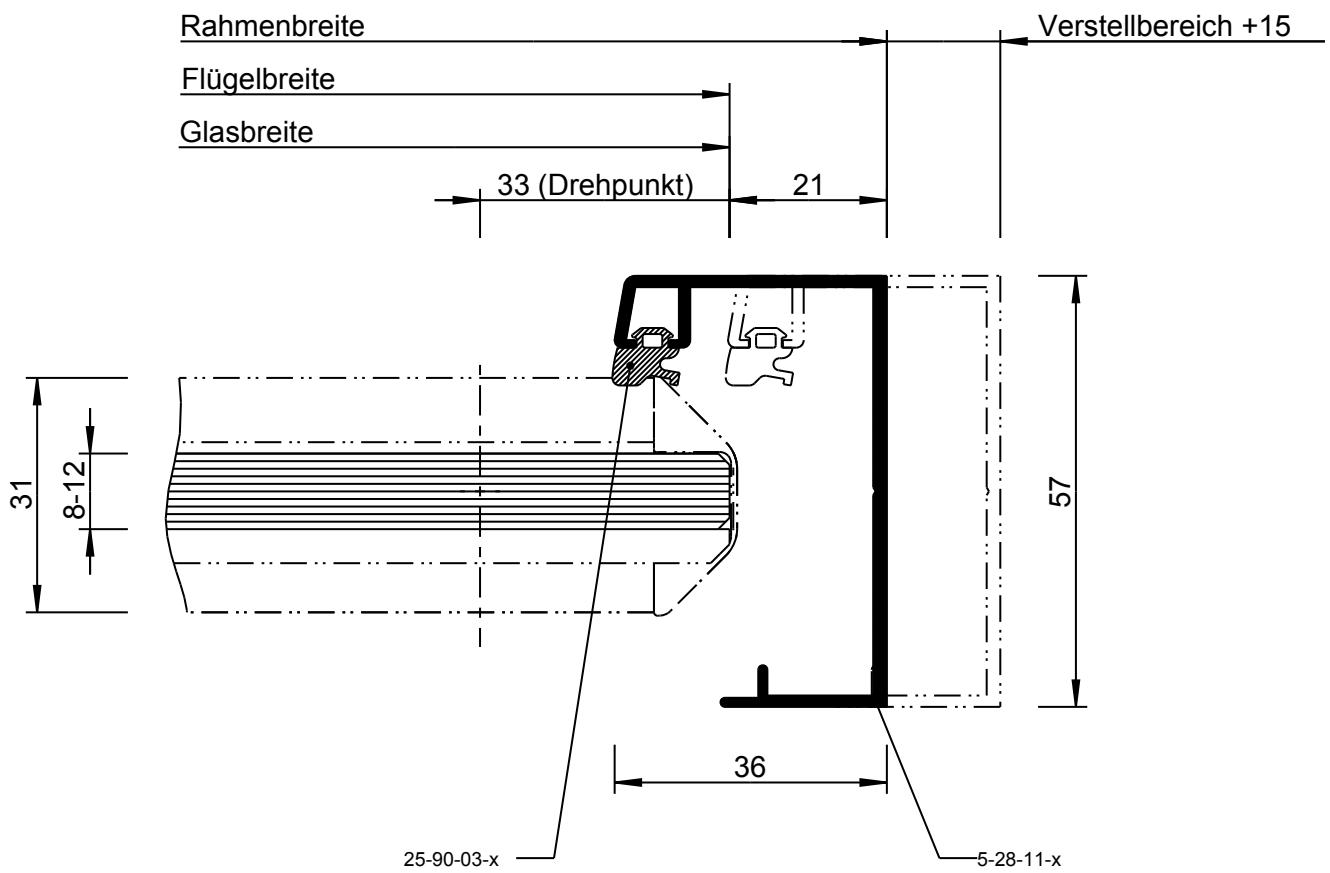

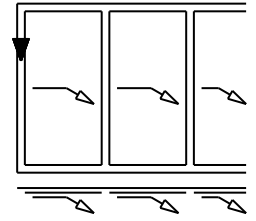

Detail 25 XXL-6-2

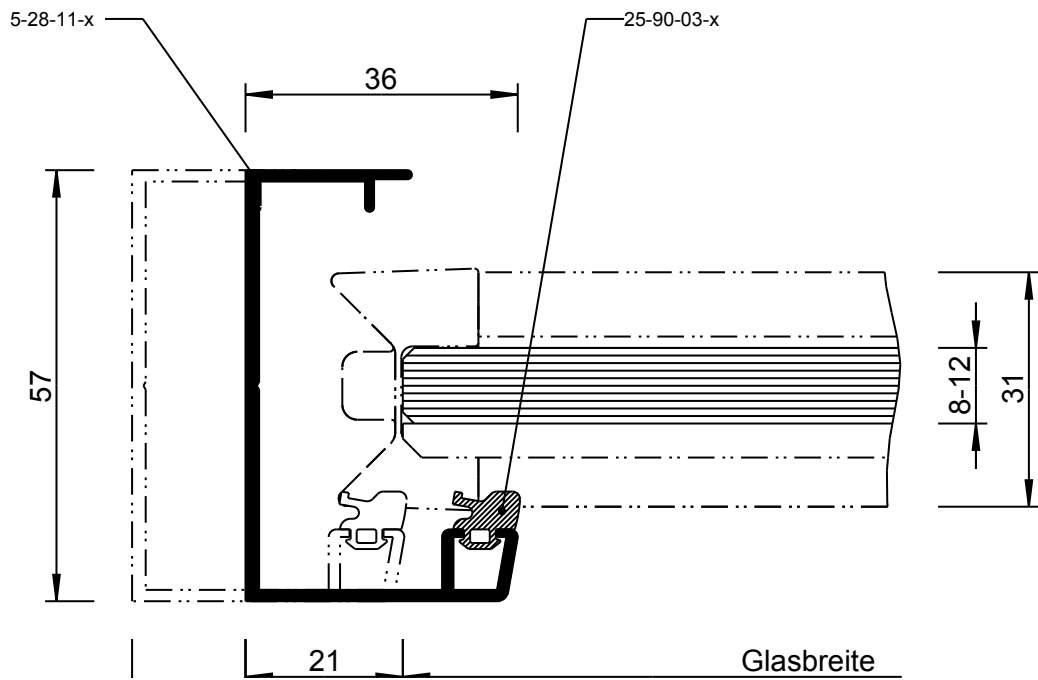

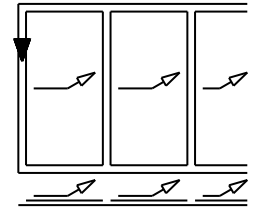

Detail 25 XXL-6-3

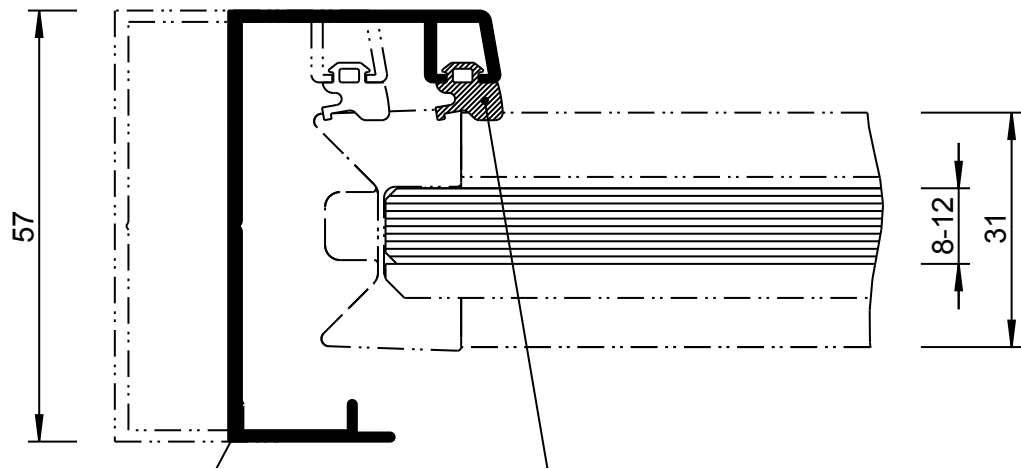
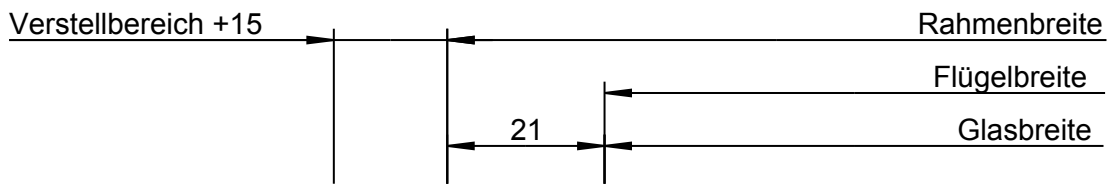

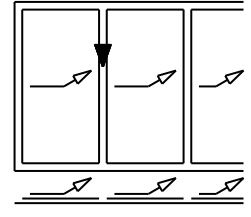
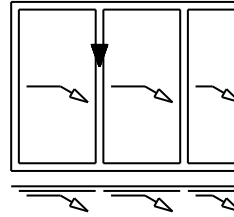

Detail 25 XXL-11-0

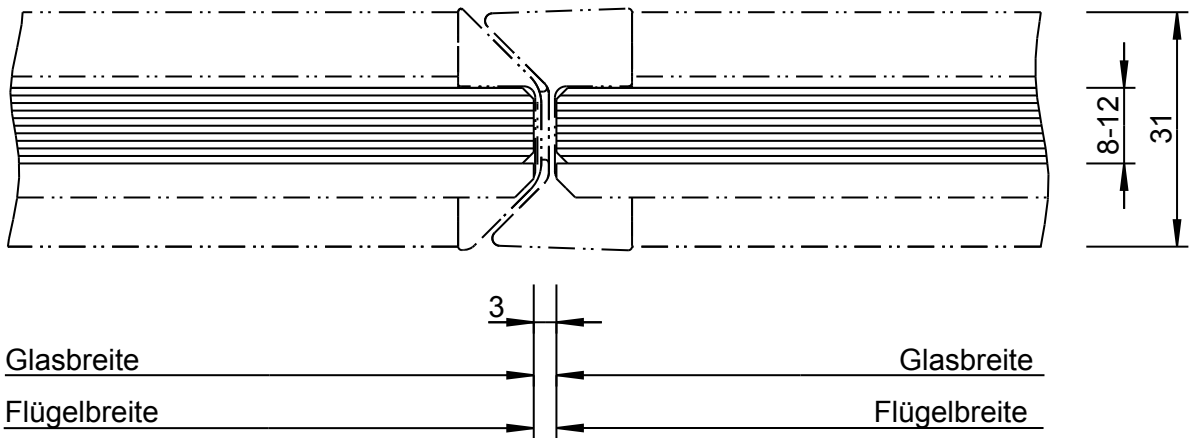

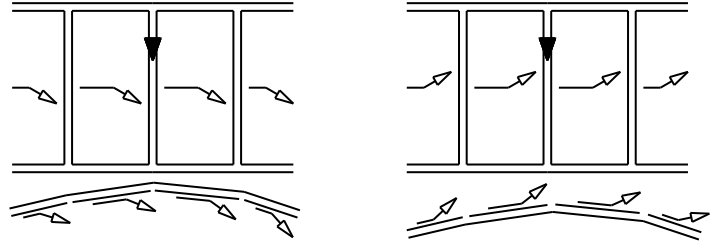

Detail 25 XXL-11-2

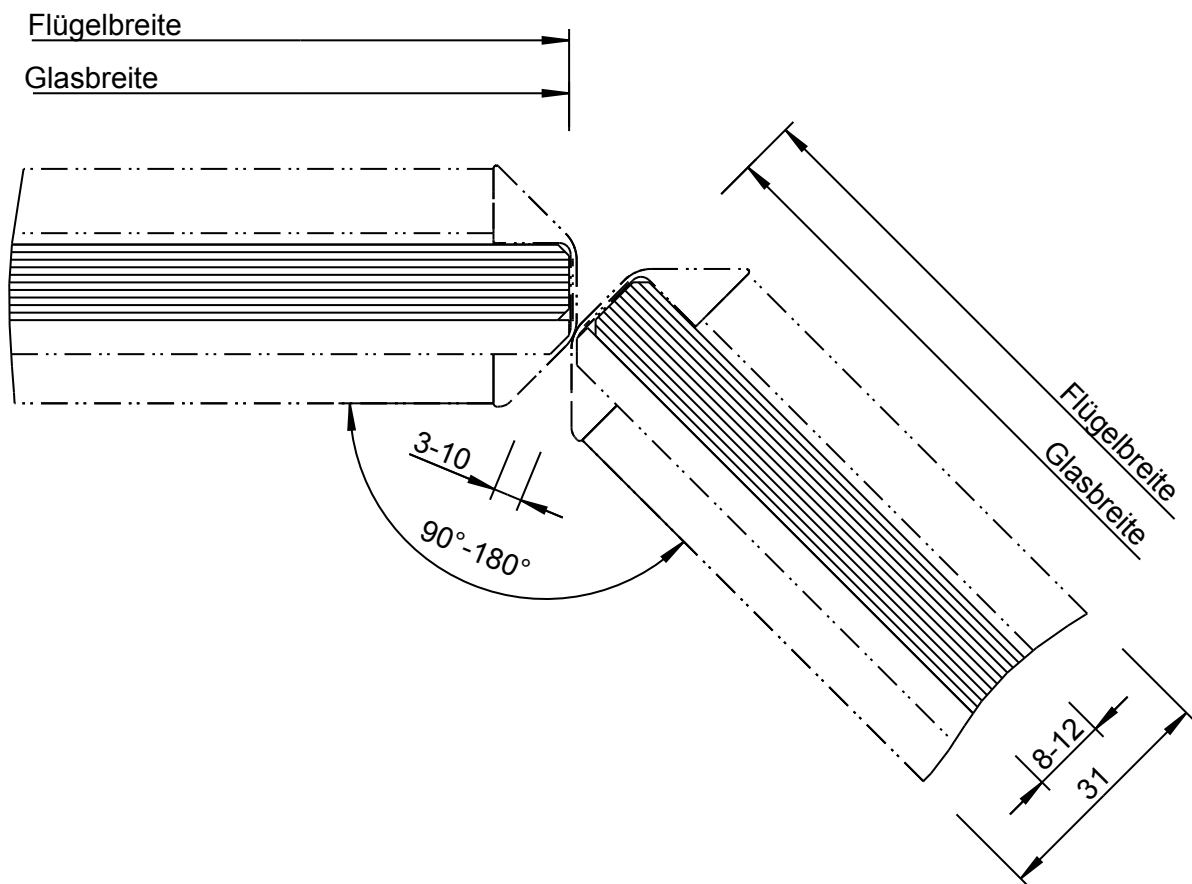

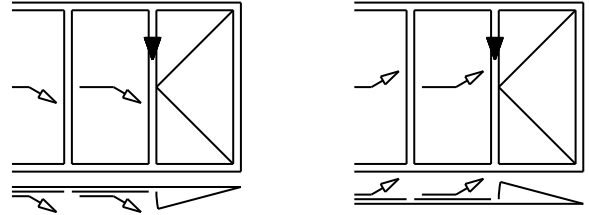

Detail 25 XXL-11-4

